

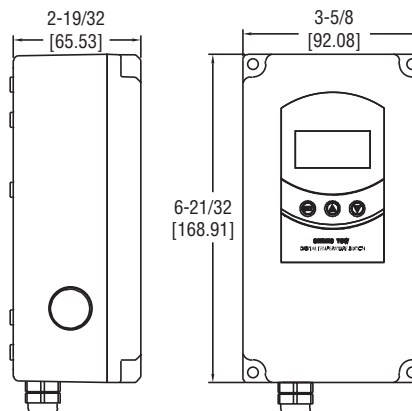

Series TSW Single Stage Digital Temperature Switch

Specifications - Installation and Operating Instructions



The **Series TSW Digital Temperature Switch** combines the trusted, reliable TS family of temperature controls and an installation friendly weatherproof enclosure. By using the same programming parameters as our Series TS2 and Series TSS2, set up can be quickly completed using the front keys or by using the TS2-K configuration key. In order to prevent tampering from unauthorized users, a parameter lock physical jumper and software passcode security are standard in the unit. The bright, easy-to-read LED display shows the current output status and the temperature measurement.

The multiple conduit knockouts on the Series TSW give flexibility to the installer to determine the best location for the conduit entry. Another installation friendly feature of the Series TSW is the ability to quickly jumper the line voltage to the common of the output relay using fast tabs.

INSTALLATION

NOTICE: The thermostat must be installed by authorized professionals. It should be located in a place free of vibrators, impacts, and corrosive gases.

NOTICE: Protective plastic overlay should be peeled off after final installation.

SPECIFICATIONS

Probe Range:

PTC: -58 to 302°F (-50 to 150°C).

NTC: -58 to 230°F (-50 to 110°C).

Input: PTC (1000Ω @ 25°C)/NTC (10KΩ @ 25°C).

Output: R1 SPDT Relay Resistive Load: 20A @ 240 VAC.

Horsepower Rating: R1 2HP @240 VAC.

Control Type: On/Off.

Power Requirements: 90 to 255 VAC or 12 to 24 VAC/VDC (±10%) depending on model.

Power Consumption: 3.6VA.

Accuracy: ±1% FS.

Display: 3 digits plus sign.

Resolution: 0.1° < 100°; 1° ≥ 100°.

Memory Backup: Non-volatile memory.

Ambient Temperature: 32 to 104°F (0 to 40°C).

Weight: 1.2 lbs (544 g).

Front Protection: NEMA 4X (IP66).

Agency Approvals: CE, UL, cUL.

WIRING INSTRUCTIONS

Wiring diagram is displayed on the inside cover of the unit and in figure 1.

NOTICE: If the length of the probe cables measures more than 100 meters, a recalibration adjustment must be made (parameter P1).

NOTICE: Avoid installing the probe cables in proximity with any power cables.

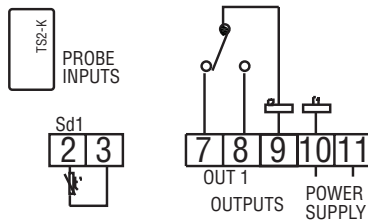

Figure 1

PROGRAMMING PARAMETERS

In order to adjust parameters, jumper must be set in unlocked position.



Figure 2

Access only to Set Points SP (without software code protection):

- Press and release SET. Parameter SP appears on the display.
- Press SET to see the value of the parameter.
- Modify the value using the UP and DOWN keys.
- Press SET Key to save the value.
- Press SET and DOWN to quit programming, or wait 1 minute for the TIMEOUT.

Access to all parameters (software code protected):

- Press SET for 8 seconds. The access code value 0 is shown on the display.
- Using the UP and DOWN buttons, set the code (factory-set code is 0).
- Press SET to confirm the code. If it is correct, the first parameter label will be shown on the display (SP).
- Move to the desired parameter with the UP and DOWN keys.
- Press SET to see the value of the parameter.
- Modify the value with the UP and DOWN keys.
- Press SET to save and exit parameter list.
- Press SET and DOWN to quit programming, or wait 1 minute for the TIMEOUT.

Resetting the parameter pass code

The parameter code can be set to zero by holding the SET key and cycling power to the unit.

LED INDICATIONS

- This indicates that the output is energized or that the compressor is connected. It waits for the programmed minimum stop time of the compressor.
- This indicates that defrosting is activated.

Error Messages

In normal operation, the probe temperature will be shown. In case of alarm or error, the following messages will be shown:

- **Er-** Memory error.
- **--** Shorted-circuited probe error.
- **oo-** Open probe error.

Parameter List

	Description	Units	Range
SP	Set Point	Degrees	r1 to r2
r0	Differential or hysteresis	Degrees	1 to 20°
r1	Lower value for set point	Degrees	-50 to 150°C -50 to 302°F
r2	Higher value for set point	Degrees	-50 to 150°C -50 to 302°F
d0	Heating or Cooling Control	Option	Ht/Co
d2	Time for Defrosting	Minutes	0 to 59
d8	Interval time between Defrosts	Hours	0 to 24
c0	Minimum stop time for compressor	Minutes	0 to 59
c1	Continuous cycle time	Hours	0 to 24
c2	On time of fault cycle	Minutes	0 to 999
c3	Off time of fault cycle	Minutes	0 to 999
P0	Engineering Units	Option	°C/°F
P1	Ambient Probe Adjustment	Degrees	-10 to 10°
H5	Parameter access code	Number	0 to 99
H6	Probe Input Type	Option	Ptc/ntc
t0	Maximum Temperature on Display	Degrees	-50 to 150°C -50 to 302°F

PARAMETER DESCRIPTIONS

SP = Set Point. Temperature desired to regulate the machine. Can vary from r1 to r2.

r0 = Differential. Heating: If temperature is \geq SP then output is OFF. If temperature is $<$ SP - r0 then output is ON. Cooling: If temperature is \geq SP + r0 then output is ON. If temperature is $<$ SP then output is OFF.

r1 = Lower Set Point Limit.

r2 = Upper Set Point Limit.

d0 = Heat or Cooling Control. Ht = heating control, Co = cooling control.

d2 = Defrosting Time Remaining, in minutes. If d2 = 0, defrosting will not start.

d8 = Interval Between Two Defrosts, in hours.

c0 = Minimum Time for Compressor to be OFF. Minimum time for compressor to stop until it can start again.

c1 = Continuous Cycle Time. The remaining time for a continuous cold cycle.

c2 = ON Time of fault cycle, during probe error.

c3 = OFF Time of fault cycle, during probe error.

P0 = Selection of Engineering units between F and C.

P1 = Ambient Probe Calibration. Offsets temperature in degrees to adjust the ambient probe.

H5 = Access Code to Parameters. Factory-set to 0.

H6 = Selection of Input Probe Type: PTC or NTC.

t0 = Temperature Display Limit. Maximum temperature shown on the display, although the real temperature can be greater.

OPERATION IN CASE OF ERROR

If the probe or thermostat memory should fail, the compressor will be connected in accordance to the parameters set in C2 and C3.

MAINTENANCE/REPAIR

Upon final installation of the Series TSW, no routine maintenance is required. The Series TSW is not field serviceable and should be returned if repair is needed. Field repair should not be attempted and may void warranty.

WARRANTY/RETURN

Refer to "Terms and Conditions of Sales" in our catalog and on our web-site. Contact customer service to receive a Return Goods Authorization number before shipping the product back for repair. Be sure to include a brief description of the problem plus any additional application notes.