



TRACON® MODEL FPT-130 SINGLE-POINT FREEZE PROTECTION HEAT-TRACE CONTROL

TABLE OF CONTENTS

FPT 130 Overview.....	2
Installation	3
Power Source and Load Connections.....	4
Temperature Sensor.....	5
External Alarm.....	5
Dip Switches.....	6
Operation	7
Specifications	9

Pilot Duty

The FPT 130 General Purpose Thermostat with GFEP cannot be used for Pilot Duty applications.

Devoir du pilote

Le thermostat à usage général FPT 130 avec GFEP ne peut pas être utilisé pour les applications Pilot Duty

Resistive Load Usage Only

This product is not for use with Inductive loads. Inductive loads may create nuisance tripping of the Ground-Fault Equipment Protection circuit.

Utilisation de charge résistive uniquement

Ce produit n'est pas destiné à être utilisé avec des charges inductives. Les charges inductives peuvent créer un déclenchement intempestif du circuit de protection de l'équipement contre les défauts à la terre.

Abnormal Odor or Smoke

In the event of smoke or a burning or abnormal odor, immediately interrupt power to the unit by turning off the circuit breaker protecting the unit.

Odeur ou fumée anormale

En cas de fumée ou de brûlure ou d'odeur anormale, coupez immédiatement l'alimentation de l'unité en fermant le disjoncteur protégeant l'unité.

Electrical Shock / Fire Hazard

Any installation involving electric heater wiring must be grounded to earth to protect against shock and fire hazard. Suitable ground fault detection and interrupting systems must always be in use to reduce shock and fire hazard and to protect equipment.

Electric wiring to heating elements must be installed in accordance with National Electrical Code (NEC)/ Canadian Electrical Code requirements, as well as all other local and applicable electrical codes and any third-party standards. This product is intended for commercial and industrial applications. Follow the installation instructions contained in this manual and those provided by the heater manufacturer. Size the circuit breaker appropriately for the expected load and inrush current. The maximum rated current for the FPT 130 is 30 amps with resistive load.

Heater loads and their controls should not share a circuit branch with other types of equipment. A shared circuit may result in electromagnetic interference that can affect system operation. Make certain that the heater shield is properly grounded. Failure to do so may result in damage to the equipment or fire.

Following installation and prior to beginning system operation, refer to and perform the Post-Installation Test described in this manual.

Risque de choc électrique / d'incendie

Toute installation impliquant un câblage de chauffage électrique doit être mise à la terre pour se protéger contre les chocs et les risques d'incendie. Des systèmes appropriés de détection et d'interruption des défauts à la terre doivent toujours être utilisés pour réduire les risques de choc et d'incendie et protéger l'équipement.

Le câblage électrique des éléments chauffants doit être installé conformément aux exigences du Code national de l'électricité (NEC) / du Code canadien de l'électricité,

ainsi qu'à tous les autres codes électriques locaux et applicables et à toute norme tierce. Ce produit est destiné aux applications commerciales et industrielles. Suivez les instructions d'installation contenues dans ce manuel et celles fournies par le fabricant de l'appareil de chauffage. Dimensionnez le disjoncteur en fonction de la charge et du courant d'appel attendus. Le courant nominal maximum pour le FPT 130 est de 30 ampères avec une charge résistive.

Les charges de chauffage et leurs commandes ne doivent pas partager une branche de circuit avec d'autres types d'équipement. Un circuit partagé peut entraîner des interférences électromagnétiques qui peuvent affecter l'opération du système. Assurez-vous que le blindage du radiateur est correctement mis à la terre. Ne pas le faire peut endommager l'équipement ou provoquer un incendie.

Après l'installation et avant de commencer le fonctionnement du système, reportez-vous et effectuez le test de post-installation décrit dans ce manuel.

ITEMS INCLUDED

QTY.	P/N	DESCRIPTION
1	25169	TRACON MODEL FPT 130 Single-Point Freeze Protection Heat-Trace Control
1	25076	Temperature Sensor
1	25298	FPT 130 Installation Sheet
-	25165	TRACON MODEL FPT-130 Installation & Operation Manual (this document)

OVERVIEW

The TRACON FPT-130 Heat-Trace Control is a microprocessor-based heat-trace control thermostat.

Ideal uses include freeze protection, and other temperature monitoring and control applications. The FPT-130 and its heater load can be powered with an available line voltage source of 100 - 277 V ac. The

controller and heater load are powered from the same supply connection. The internal load contactor are rated to switch up to 30 A resistive. The GFEP function provides additional safety and compliance with national and local electrical codes. The unit's housing is a NEMA 4X IP66 weather-resistant enclosure for enhanced durability.

FEATURES AND BENEFITS

- Adjustable temperature set point of 30 °F, 38 °F, 45 °F, or 50 °F (–1.1 °C, 3.3 °C, 7.2 °C, or 10 °C) for various freeze protection applications
- Can use an NEC Class 2 temperature sensor with up to 2,000 ft. cable for enhanced installation options
- Thermistor temperature sensor with 20 ft. cable included for applications of –40 °F to 230 °F (–40 °C to 110 °C)
- Ground-Fault Equipment Protection with manual and automatic test function
- Alarms for excess ground fault current, low load current, and temperature
- Alarms indicated with panel LED lights and relay contact for remote signaling
- A Fault Mode setting which can be set to energize or de-energize the heaters during a sensor failure
- Fire Protection Mode maintains heater operation for use in critical fire protection systems
- Durable weather-resistant NEMA 4X IP66 enclosure permits indoor or outdoor installation

The FPT 130 is permanently connected equipment and does not have an internal disconnect device. The installer must provide an accessible disconnect device, with short circuit and overcurrent protection (these are not supplied by Environmental Technology Inc). When power is applied, the system will start.

INSTALLATION

The FPT 130 Automatic Heat-Trace Control should be installed by a qualified, licensed electrician. Installation must conform to all applicable local and national electrical codes and laws. The unit's NEMA 4X IP66 enclosure allows for indoor or outdoor applications.

The FPT 130 controller has an ambient operating temperature range of -40°F to 131°F (-40°C to 55°C). To avoid potential internal condensation mount the unit out of direct sunlight.

Install the FPT on a fixed, flat, vertical surface using the unit's mounting flanges. The mounting flanges accommodate $1/4"$ or 6.3 mm fasteners.

The FPT 130's nonmetallic enclosure has one $1.046"$ hole for conduit entry; this can hold both power and load wiring.

Use only Listed Type 4X IP66 liquid-tight conduit hubs or cable glands. Connect the hub to the conduit system before connecting the hub to the enclosure.

The unit comes with two installed liquid-tight cable glands. One of these fittings is for the temperature sensor cable, and the other is for the alarm relay cable.

The cable glands can accommodate cable diameters $0.08"$ to $0.24"$ (2 mm to 6 mm). The temperature sensor may be located up to 2,000' (610m) from the FPT.

There is a removable electrical insulation divider that must be in place when there is power applied to the unit. All leads should be terminated; no unsecured leads should be left inside the wiring compartment.

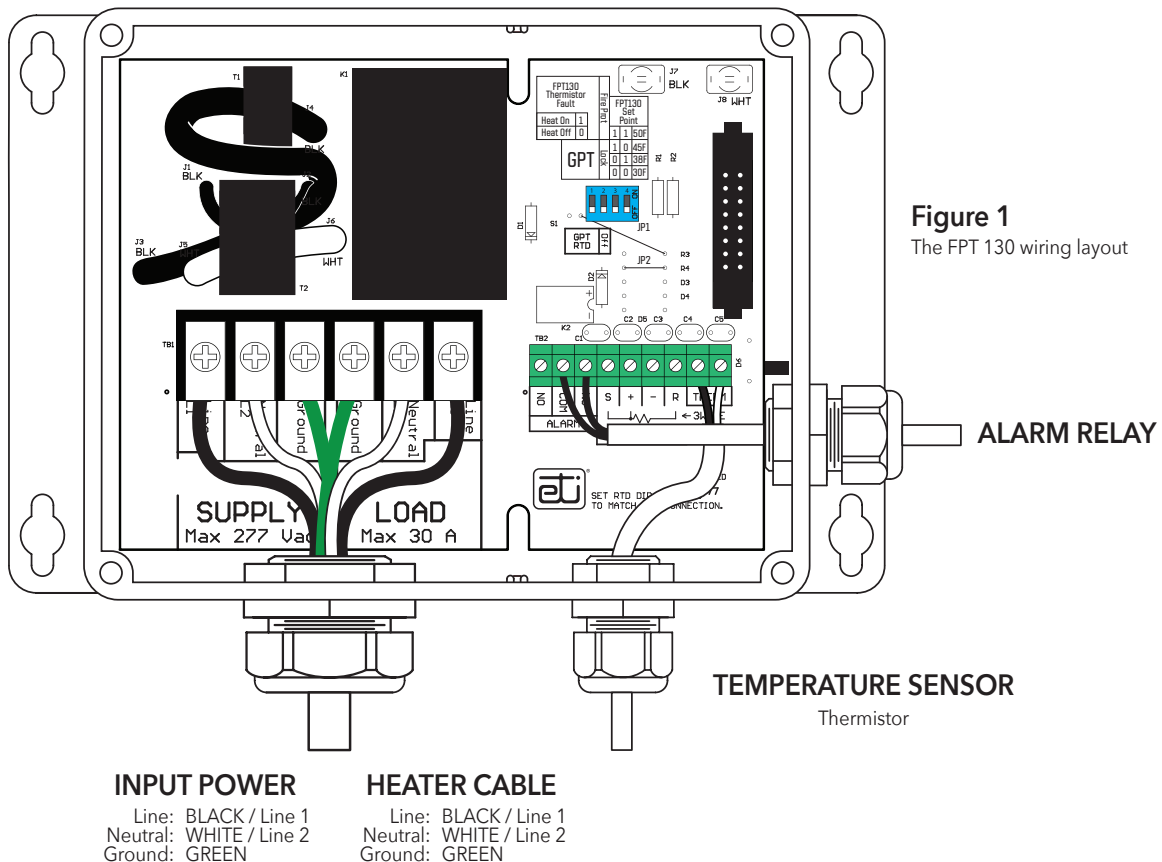

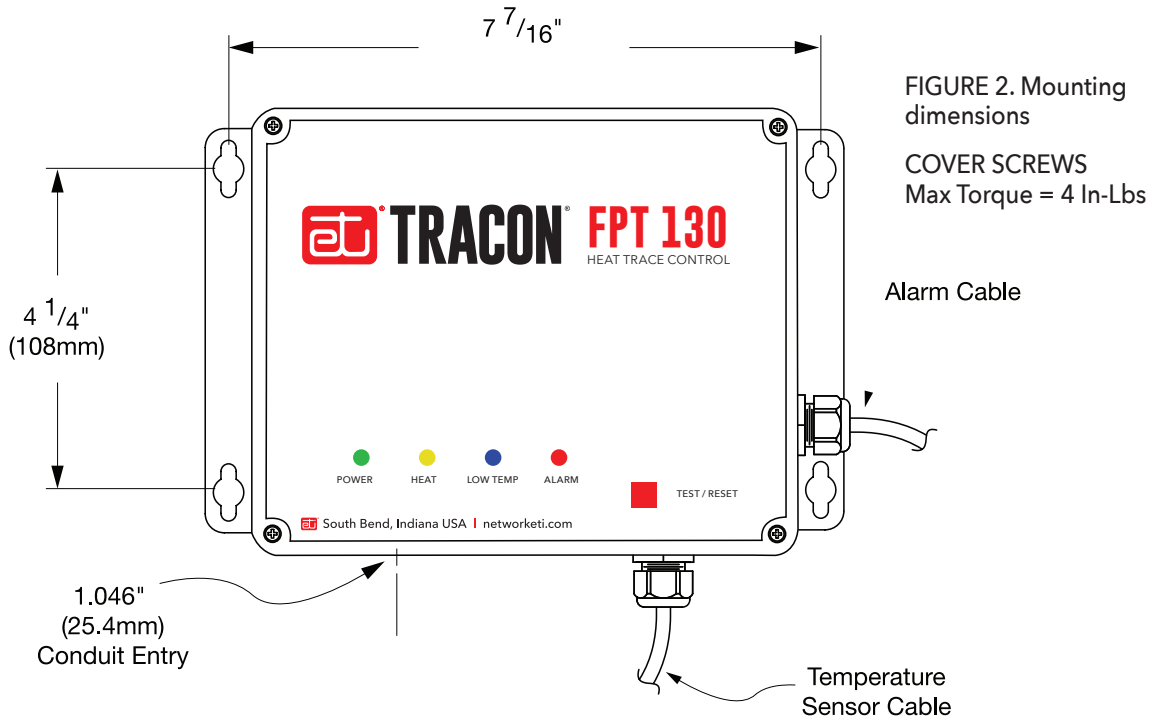

POWER SOURCE AND CONTACTOR CONNECTIONS

Supply Voltage

The FPT 130 operates from 100 - 277 V ac at 50/60 Hz. This control and its heater load should not share a circuit branch and circuit breaker with other types of equipment. A shared circuit may result in electromagnetic interference that can affect system operation. For line supply and load connections, use 10 AWG wires rated for at least 194 °F (90 °C). The connections are shown in Figure 3 and Figure 4.

Contactors Ratings

The heater contactor provides dual Form A (DPST) contacts rated for heater loads up to 30 amps and 277 volts ac. The dual contacts on the contactor are used to control both legs of the input power (Line and Neutral).

Manual Load Test

To manually energize the load, hold Test/Reset pushbutton for five seconds. The output will switch on and stay on for five minutes, or until Test/Reset pushbutton is pressed again. A manual load test is recommended upon installation to verify the heater function and load current.

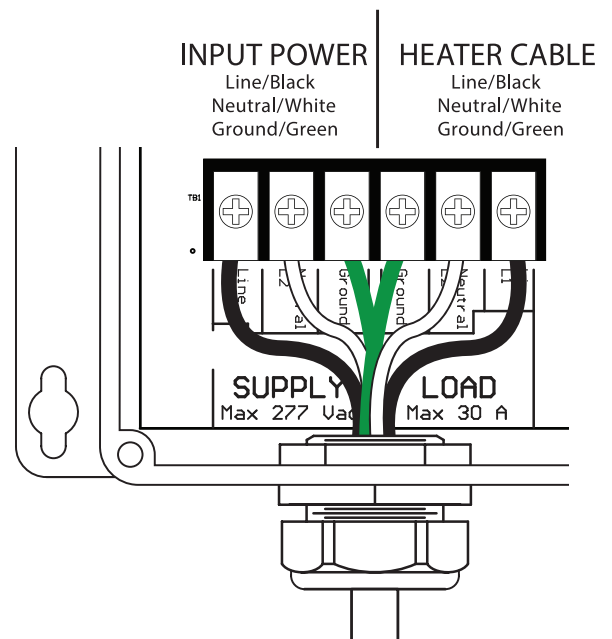
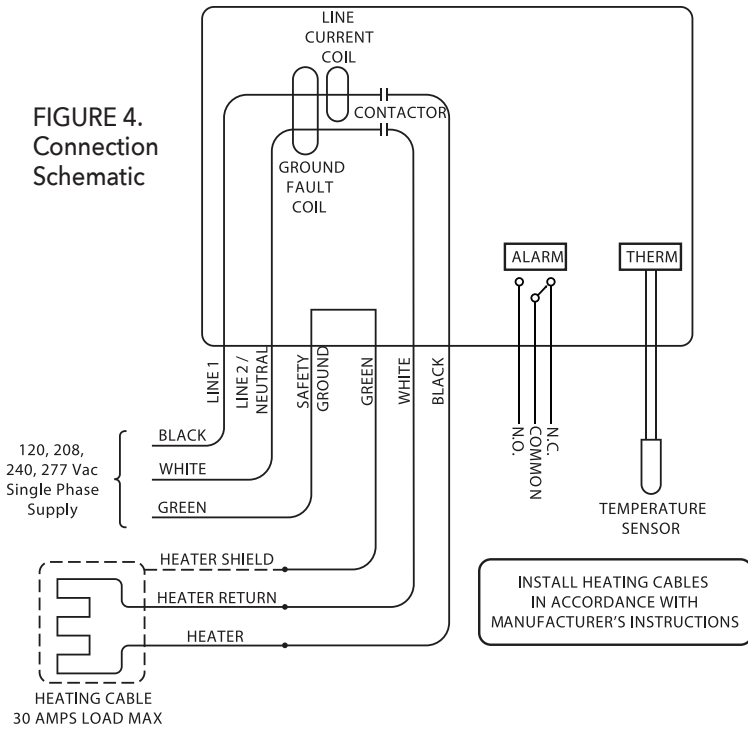

FIGURE 3. Contractor Connections

FIGURE 4. Connection Schematic



TEMPERATURE SENSOR

Thermistor (25076)

The FPT 130 comes with a thermistor temperature sensor with a 20 ft. jacketed cable that has an operating range of -40°F to 230°F (-40°C to 110°C). See Figure 5 for proper wiring for the thermistor sensor.

EXTERNAL ALARM

Alarm Connections

An alarm or power-off condition can be communicated by either opening or closing a relay contact. It is important to make the proper alarm relay connections to achieve the desired result. The middle terminal labeled COM (Common) is used in both wiring configurations. Connect one alarm relay lead to the COM terminal.

If the system needs a contact to close to signal an alarm or power-off condition, connect the other alarm relay lead to the **NC (Normally Closed)** terminal. See Figure 6.

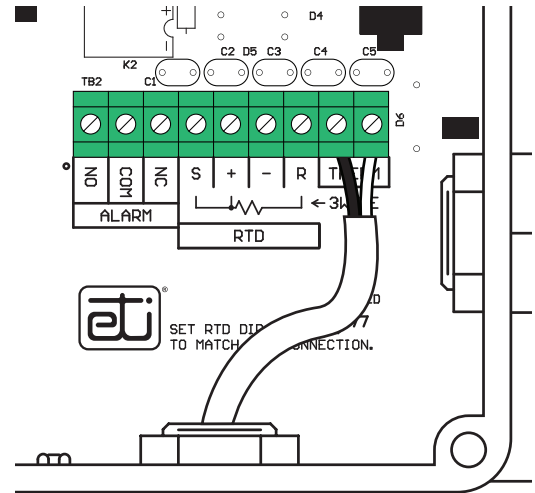

FIGURE 5. Thermistor sensor connection

Wiring to Normally Closed alarm contact

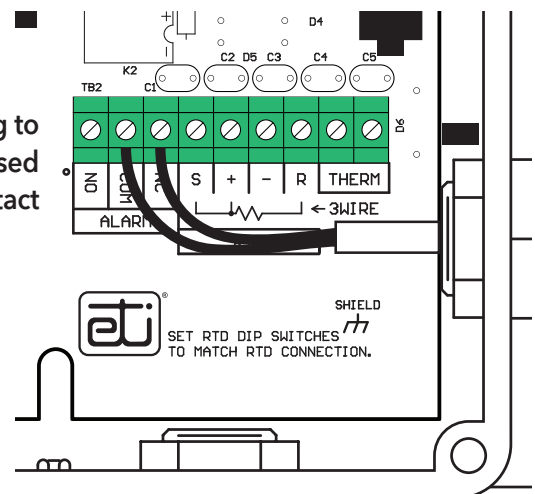

FIGURE 6. External alarm connection

If the system needs a contact to open to signal an alarm or power-off condition, then connect the other alarm relay lead to the **NO (Normally Open)** terminal.

If the unit has power, and there are no alarm conditions then the NO and COM terminals will be connected. If the unit loses power or an alarm condition occurs then the NC and COM terminals will be connected.

Note: The “Normally” condition of the relay is the alarm condition for the unit.

DIP SWITCH SETTINGS

Default settings

FIGURE 7. FPT 130
DIP switch identification

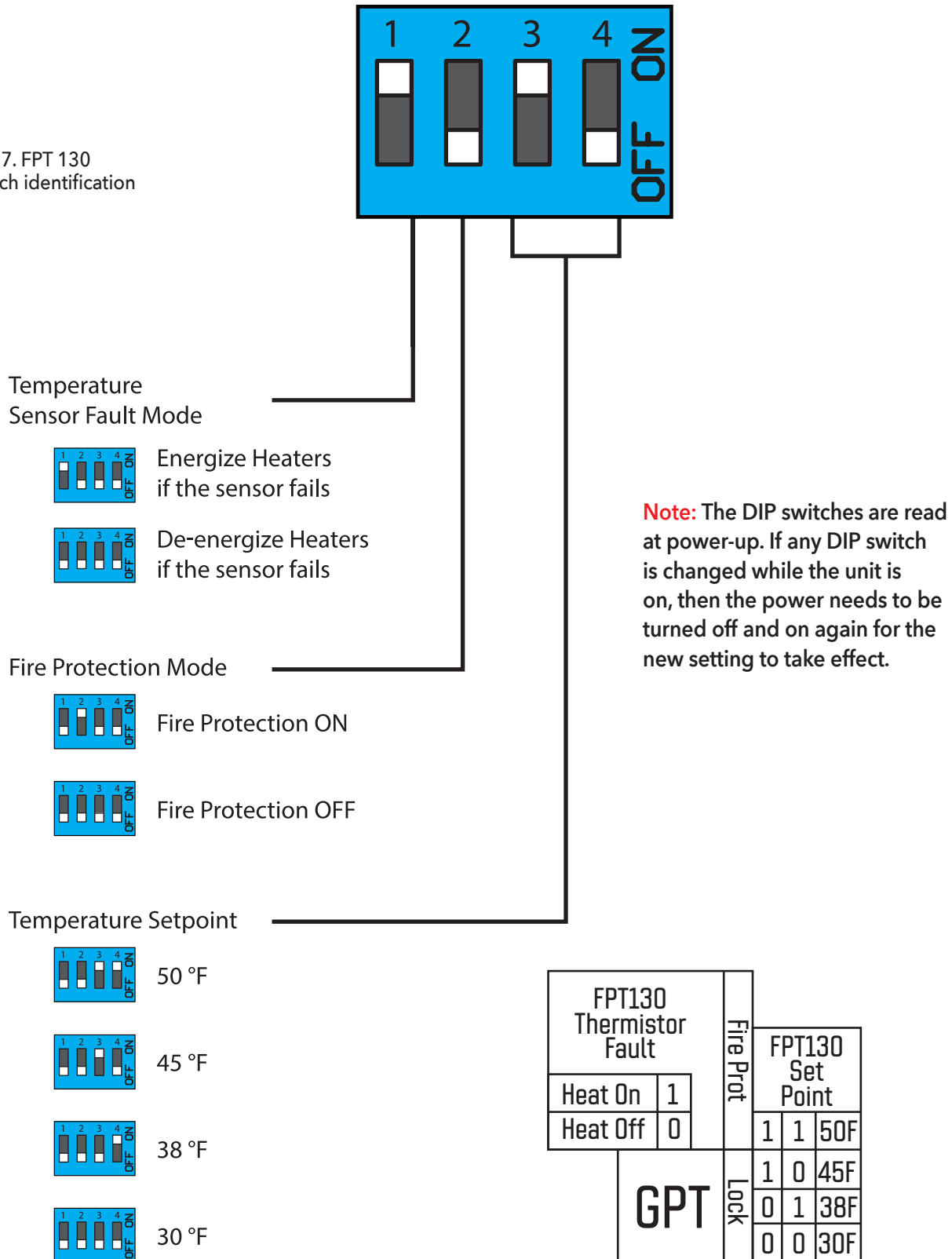

OPERATION

The FPT 130 can maintain temperatures at setpoints of 30 °F, 38 °F, 45 °F, or 50 °F (-1.1 °C, 3.3 °C, 7.2 °C, or 10 °C). The heater will energize when the temperature drops below the designated setpoint. The heater will de-energize when the temperature reaches 2 °F (1 °C) above the setpoint.

The FPT 130 features ETI's patented self-testing GFEP, which switches the system off when it detects excessive ground current leakage (unless Fire Protection Mode is on). The GFEP eliminates the extra expenses associated with having to provide external GFEP.

The FPT 130 also features a Low Current Alarm, which switches the system off when it detects a load current below 0.1 amps (unless Fire Protection Mode is on). The load current is checked during each ground fault test, and whenever the load is on. Note: the low-current alarm takes five seconds of low current to activate.

FPT 130 Front Panel

Indicator Lights (See Figure 8.)

- POWER indicator - This green LED lit solid indicates that the FPT 130 is receiving power.
 - Blinking indicates a calibration error.
- HEAT indicator - This yellow LED lit solid indicates when the heater is energized.
 - Blinking asymmetric (1/2 sec off × 1-1/2 sec on) - Low Current Alarm, heater relay closed.
 - Blinking asymmetric (1/2 sec on × 1-1/2 sec off) - Low Current Alarm, heater relay open.
 - Blinking fast - Stuck relay.
- LOW TEMP indicator - This blue LED lit solid indicates when the temperature falls to 32 °F (0 °C) for all setpoints except the 30 °F (-1.1 °C) setpoint. For the 30 °F (-1.1 °C) setpoint the LOW TEMP alarm will indicate when the temperature drops to 28 °F (-2.2 °C).
 - Blinking indicates sensor fault.
 - Blinking fast - indicates High Temperature alarm.

- ALARM indicator - This red LED lit solid indicates when there is a high ground fault current.
 - Blinking indicates a GFEP circuit failure (this light will also blink while system is performing a self-test).

Pushbuttons

- TEST/RESET pushbutton - This red pushbutton has the following functions:
 - To test the ground fault detector circuit itself AND to test for a ground fault when the heat load is not energized (the heater will energize during the test). Note: whenever the heat is on, the unit is continuously checking for a ground fault.
 - To reset the system after a ground fault. If the ground fault no longer exists, then normal operation will resume.
 - To reset the low-current alarm. If the load current is still below 0.1 amps then the alarm will recur in five seconds. Note: the low-current alarm takes five seconds of low current to activate.
 - Energizes heater for system testing or troubleshooting. Pressing this pushbutton for five seconds will energize the heater for five minutes. Pressing the push button again will de-energize the heater and resume normal operation.

Note: Because the unit has no ON/OFF power switch, power runs to the unit as soon as facility power is connected to it. When the unit has power, the green POWER indicator will be lit.

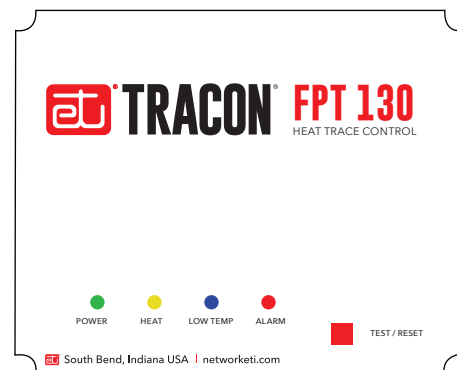

FIGURE 8. FPT 130 front panel

DISABLING THE LOW TEMP ALARM LED

The blue LOW TEMP alarm LED indicates the presence of Low Temperature, High Temperature, or a bad thermistor. When disabled this blue LED will only indicate for the presence of a bad thermistor.

How To Disable The Low Temp Alarm LED

- Hold down the red TEST/RESET pushbutton for approximately ten seconds.
 - After the first five seconds the unit will go into Manual Mode, energizing the heater cable if it is not all ready energized.
 - After the second five seconds the unit will enter the LOW TEMP blue LED edit mode. This is indicated by the blue LED flashing rapidly. Release the button at this point. (The unit will exit Manual Mode.)

Note: The blue LED may flash for a couple of seconds after releasing the red TEST/RESET pushbutton.

- The blue LED will indicate whether the LOW TEMP Alarm is currently disabled or not.
 - If the blue LED remains on the LOW TEMP Alarm is currently enabled.
 - If the blue LED goes off the LOW TEMP Alarm is currently disabled.
 - To keep the setting as it is wait five seconds and the unit will resume normal operation.
 - To change this setting press the red TEST/RESET pushbutton within five seconds. The new status of this setting will show for three seconds before the unit resumes normal operation.

Note: The blue LED will flash rapidly before exiting the LOW TEMP blue LED editing mode and resuming normal operation.

SPECIFICATIONS

General

Certifications	UL 60730-1, UL 1053, CSA E60730-1:13
----------------	--------------------------------------

Environmental

Area of use	Nonhazardous locations
-------------	------------------------

Operating temperature range	-40 °F to 122 °F (-40 °C to 50 °C)
-----------------------------	------------------------------------

Enclosure

Dimensions	8 1/8" (W) x 5 1/5" (H) x 4 3/8" (D) 207 mm (W) x 140 mm (H) x 112 mm (D)
------------	--

Ingress protection	NEMA 4X, IP66
--------------------	---------------

Cover attachment	Polycarbonate cover, plastite screws
------------------	--------------------------------------

Cable entries	Two liquid-tight cable glands installed for sensor and alarm leads, cable diameter 0.08" to 0.24" (2 mm to 6 mm) One 1.046" hole to accommodate a 3/4" conduit fitting for power wiring connection
---------------	--

Material	Polycarbonate
----------	---------------

Weight	2.7 lb. (1.22 kg)
--------	-------------------

Mounting	Wall mount with flanges
----------	-------------------------

Wiring Terminal Ratings

Power	Barrier Strip Terminals for Line, Neutral, and Ground; use 10 AWG wires rated for at least 194 °F (90 °C)
-------	---

Sensors	Terminal Block, rising cage clamp, 12-28 AWG leads
---------	--

Alarm relay	Terminal Block, rising cage clamp, 12-28 AWG leads
-------------	--

Parameter Settings

Temperature setpoints	30 °F, 38 °F, 45 °F, or 50 °F (-1.1 °C, 3.3 °C, 7.2 °C, or 10 °C)
-----------------------	---

Low-temperature threshold	32 °F (0 °C) for 38 °F, 45 °F, or 50 °F (3.3 °C, 7.2 °C, or 10 °C) setpoints 28 °F (-2.2 °C) for 30 °F (-1.1 °C) setpoint
---------------------------	--

High-temperature threshold	90° F above setpoint
----------------------------	----------------------

Low-current alarm delay	5 s
-------------------------	-----

Ground fault limit current	30 mA
----------------------------	-------

Self-Test Interval	24 h
--------------------	------

User Interfaces

Pushbuttons	Test/Reset
-------------	------------

DIP switches	Temperature setpoint Thermistor fault mode Fire protection mode
--------------	---

Remote Interface

Alarm relay	Isolated SPDT 1 AMP Class 2 contact
-------------	-------------------------------------

Indicators

Status indicator	Power to the unit (Green solid) Calibration error (Green blinking) Call for heat (Yellow solid) Low current alarm (Yellow blinking) Stuck relay (Yellow blinking fast) Low temperature (Blue solid) High temperature (Blue Blinking-FAST) Sensor fault (Blue blinking) Ground fault (Red solid) GFEP circuit failure (Red blinking)
------------------	--

Summary alarm relay reporting	Low load current High ground fault current Sensor fault Internal fault
-------------------------------	---

Control Ratings

Temperature accuracy	+/- 2 °F (1 °C)
----------------------	-----------------

Temperature Sensors

Temperature inputs	(Included) Thermistor, 100k ohms at 25 °C, range -40 °F to 230 °F (-40 °C to 110 °C), 20ft Lead (25076)
--------------------	---

GFEP (Ground-Fault Equipment Protection)

Threshold	30 mA
-----------	-------

Automatic self-test range	Verifies GFEP functionality every 24 hr. and whenever the load is turned on
---------------------------	---

Power

Supply voltage	100 - 277 V ac 50/60 Hz
----------------	-------------------------

Controller power consumption	5 W maximum, 2 W idle
------------------------------	-----------------------

Load rating	30 A, 100 - 277 V ac resistive
-------------	--------------------------------

Specifications are at 77 °F (25 °C) unless otherwise stated and are subject to change without notice.

ORDERING INFORMATION

Part Number	Description
25169	TRACON MODEL FPT 130 Single-Point General Purpose Heat-Trace Control
25076	Temperature Sensor
25298	FPT 130 Installation Sheet
25165	TRACON MODEL FPT-130 Installation & Operation Manual (this document)

LIMITED WARRANTY

ETI's two year limited warranty covering defects in workmanship and materials applies. Contact Customer Service for complete warranty information.

DISCLAIMER

ETI makes no representations or warranties, either expressed or implied, with respect to the contents of this publication or the products that it describes, and specifically disclaims any implied warranties of merchantability or fitness for any particular purpose. ETI reserves the right to revise this publication, and to make changes and improvements to the products described in this publication, without the obligation of ETI to notify any person or organization of such revisions, changes or improvements.

RETURNS AND REPLACEMENT PART PURCHASES

Equipment cannot be returned for credit once it has been installed. ETI will repair or replace faulty equipment under warranty. Prior to removal of equipment for warranty return, please contact ETI Technical Support for troubleshooting assistance.

Before returning a unit to ETI, obtain a Return Merchandise Authorization from our Customer Service Department, available between 8:00 a.m. and 5:00 p.m. Eastern Time. If possible, use the original container and packing materials when packing the unit for shipment. It is important to mark the Return Merchandise Authorization clearly on the outside of the shipping container so that it may be correctly processed upon receipt at Environmental Technology. For more information about replacement parts or for a replacement Data Sheet or Manual, please visit www.networketi.com.