

Installation Instructions

DTS-HAZ DTS-HAZ-DC

for use with Self-Regulating, Constant Wattage &
Mineral Insulated Electric Heating Cables



PJ944-10
5625-81049
May 2015

DTS-HAZ & DTS-HAZ-DC

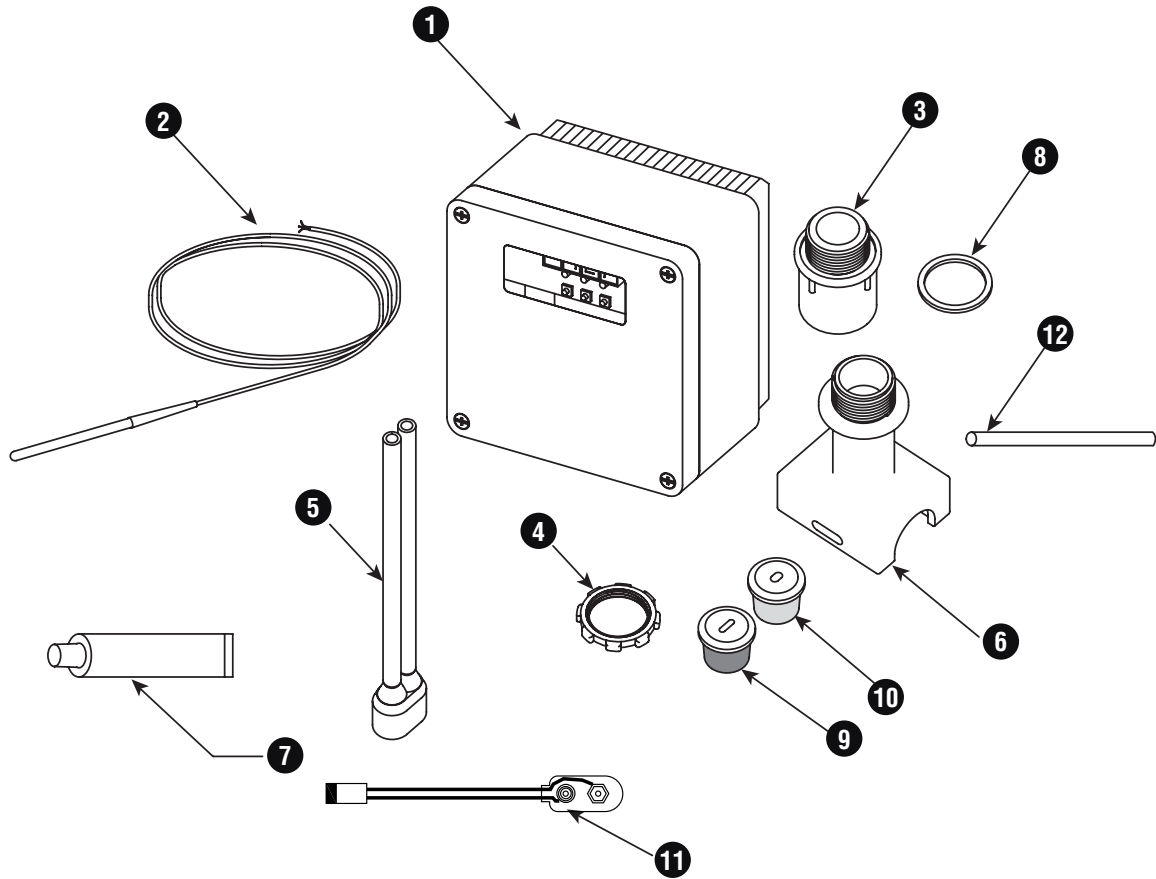

Item	Qty	Description	Item	Qty	Description
1	1	Control Unit / Junction Box	7	1	RTV
2	1	Line/Ambient Sensing RTD	8	1	O-Ring
3	1	Compression Fitting	9	1	Self-Regulating Cable Grommet
4	1	Locknut	10	1	Constant Wattage Cable Grommet
5	1	Silicone Termination Boot	11	1	9 VDC Battery Connector
6	1	Pipe Standoff	12	1	Protective Sleeve

General

The DTS-HAZ and DTS-HAZ-DC units are used for temperature control and electrical termination of self-regulating, constant wattage and mineral insulated (MI) electric heating cables. Each kit contains the terminations needed to make all electrical connections.

The DTS-HAZ (or DTS-HAZ-DC) digital thermostat kit is a microprocessor based temperature control and power connection kit used for freeze protection or process temperature maintenance of pipes or tanks protected by heat tracing products. This thermostat can be used in ordinary areas as well as Class I, Div 2 or IECEx/ATEX hazardous area locations.

Explanation of Symbols Used:

 Means **WARNING**.

 Means Earth (ground) terminal.

⚠ WARNING

HAZARD OF ELECTRIC SHOCK. Disconnect all power before starting. All installations must be effectively grounded in accordance with the National Electrical Code to eliminate shock hazard.

⚠ WARNING

Turn off power before removing junction box cover at all times.

⚠ WARNING

Users should install adequate controls and safety devices with their electric heating equipment. Where the consequences of failure may be severe, back-up controls are essential. Although the safety of the installation is responsibility of the user, Chromalox will be glad to assist in making equipment recommendations.

⚠ WARNING

Do not open when energized. Do not separate when energized.

⚠ WARNING

A disconnect device and circuit breaker should be provided in the end installation. The installation and proximity for the disconnect device must satisfy the electrical Authority having jurisdiction for the installation. Branch circuit protection should be set for 40 amps or lower.

⚠ WARNING

In all cases where the symbol is used on the product, consult the documentation to find out the nature of the potential hazard and any actions to be taken.

**Cable installation instructions: SRL, SRF, SRM/E, SRP
CWM cable special instructions denoted by ***

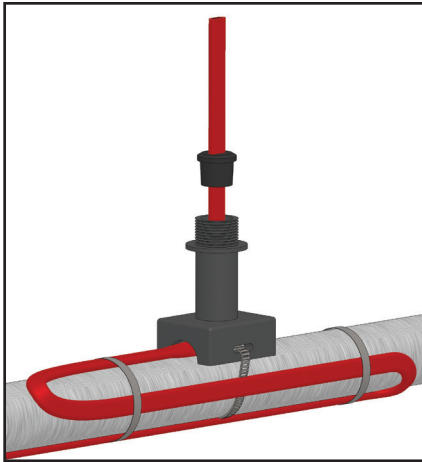

1. Insert heating cable through pipe standoff and proper grommet as shown. 8 inches of cable should extend past the grommet. Strap pipe standoff to pipe with pipe strap (Chromalox type PS not included) and attach extra cable to pipe as appropriate. If the provided RTD is to be fed through the standoff pipe, a small slice will need to be made to the outer edge of the top of the grommet. For pipes smaller than 1-1/2" diameter a small pipe adapter (Chromalox model SPA not included) is required.

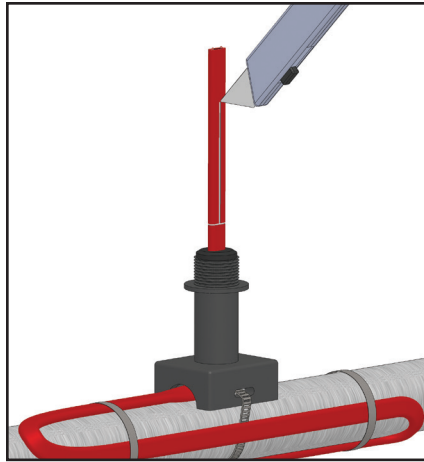

2. Score the outer insulation 7 inches from the end of the cable. Lightly cut the outer jacket up the center to the end of heating cable and remove the outer jacket from the cable. **WARNING: DO NOT CUT METAL BRAID.**

Note: If using over braid only cable, skip this step.

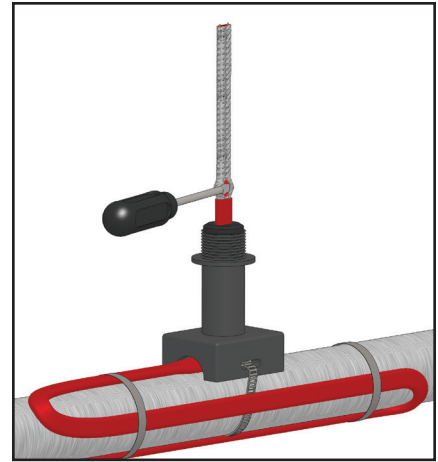

3. Move braid back toward the overjacket, creating a bulge. At the bulge, separate the braid to make an opening.

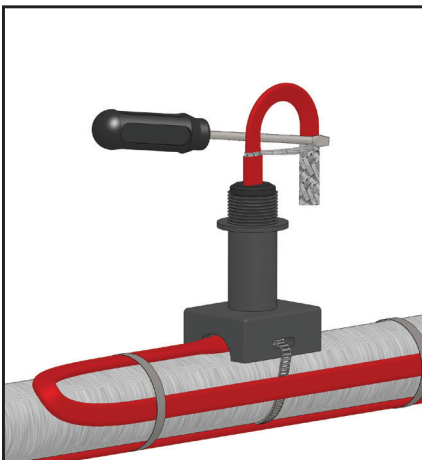

4. While bending the heating cable, work the cable through the braid opening. Pull the braid tight.

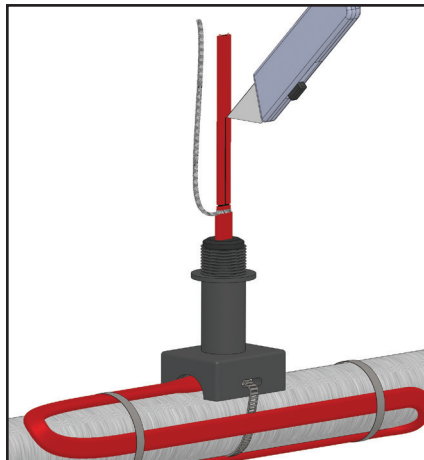

5. Score the inner insulation 6 inches from the end. Lightly cut the inner jacket up the center to end of heating cable and remove the inner jacket from the cable.

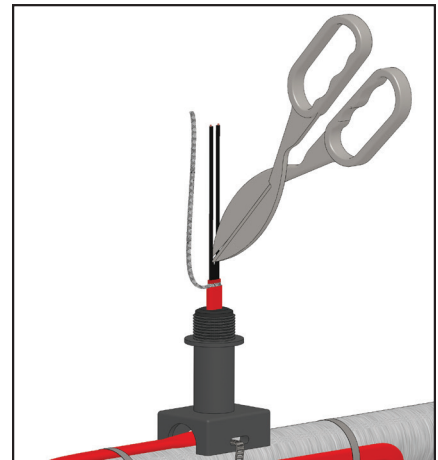

6. Use tin snips or similar tool to cut excess material from between the buss wires.

*Separate CWM leads and strip 1/4" from each lead wire.

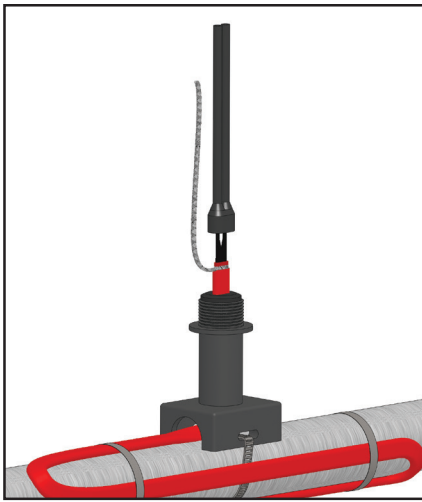

7. Liberally apply RTV over the exposed matrix and leads. Push the rubber boot over the heating cable.

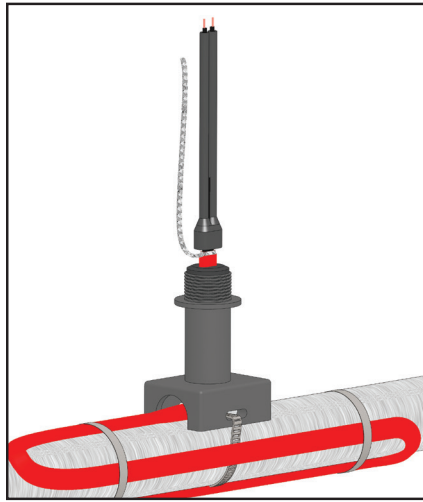

8. Strip each bus wire so that no black matrix material shows above the end of the rubber boot. Trim lead ends as needed.

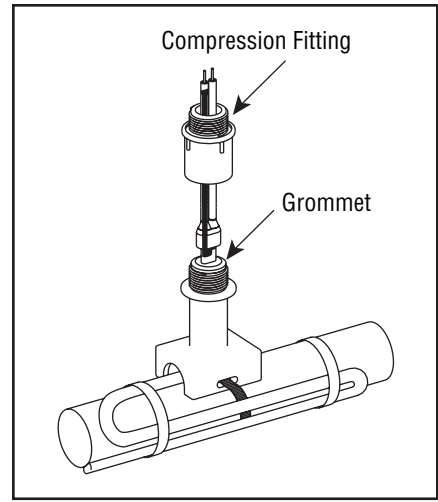

9. Slide compression fitting over cable. Grommet should be placed inside pipe standoff. Termination boot should be spaced 1/2" from sealing grommet. Tighten compression fitting until it bottoms out against pipe standoff.

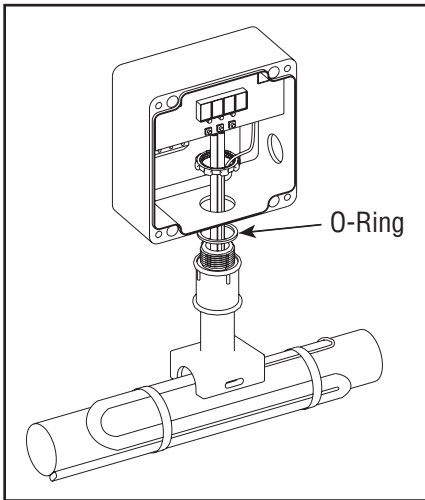

10. Seat O-Ring into compression fitting groove at base of threads. Ensure O-Ring is not twisted. Assemble junction box to compression fitting as shown. Tighten locknut until the junction box bottoms out against the lip of the compression fitting.

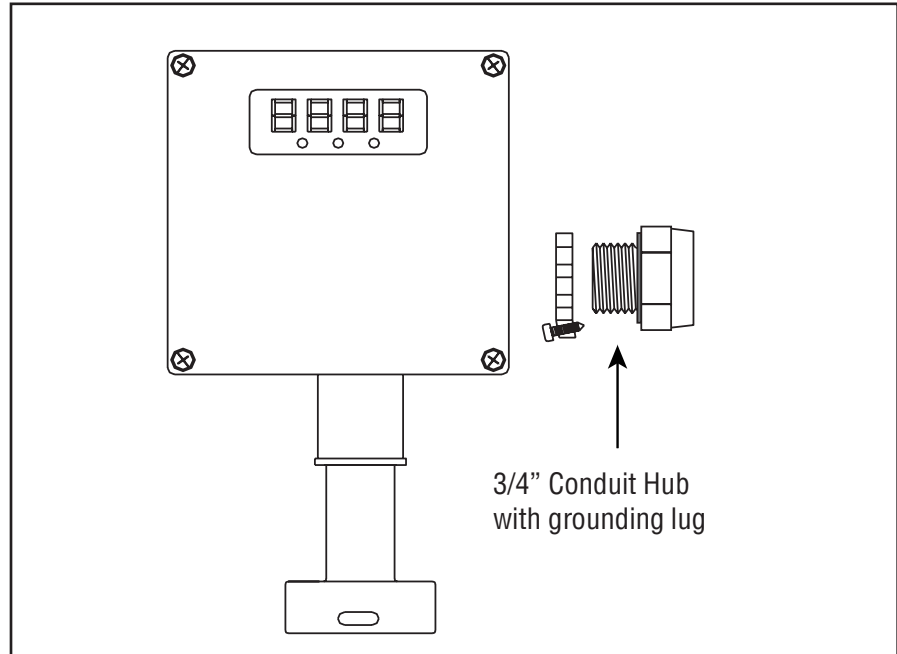

11. Please see the electric diagram for proper wiring for your application. For over-jacketed cable with internally grounded braid: Grounding braid shall have the included protective sleeve slid over it once inside the enclosure. Then, insert grounding braid into grounding terminal. Attach junction box cover to seal enclosure. Access hole on right is designed for a 3/4" conduit hub. **Note:** The conduit hub shall be listed for Class 1, Div. 2; Class II Div. 1 & 2, Class III, Div. 1 & 2, and NEMA 4X rated by a nationally recognized testing laboratory. For ATEX or IECEx installations, the conduit hub must be certified to ATEX or IECEx.

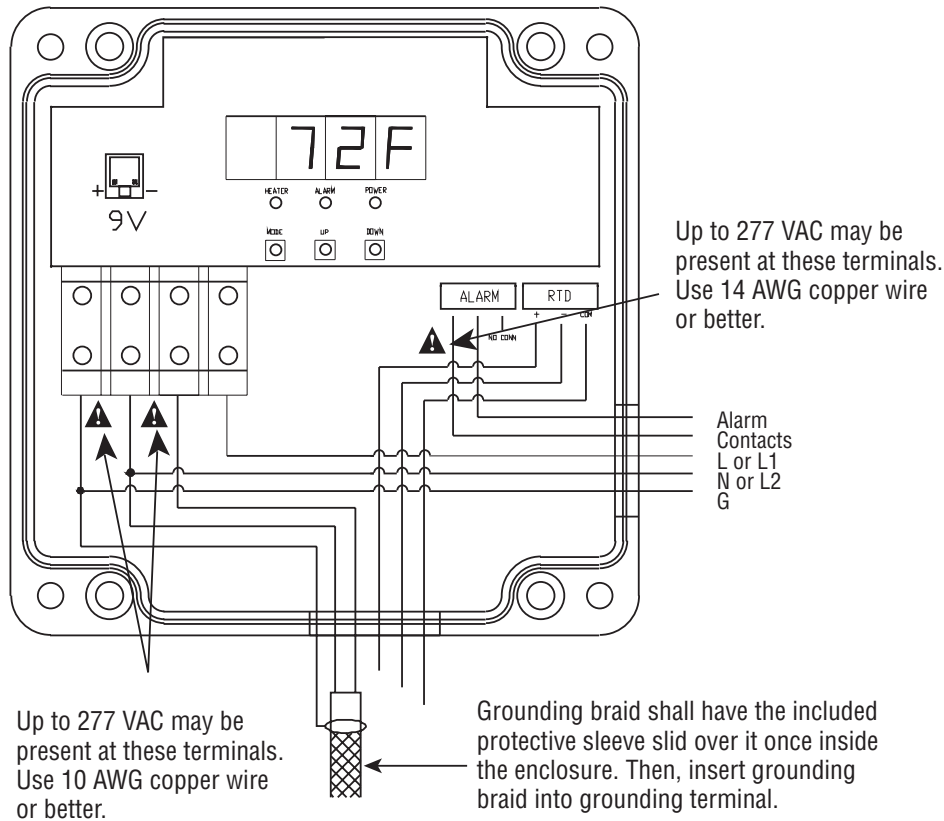

Up to 277 VAC may be present at these terminals. Use 10 AWG copper wire or better.

Grounding braid shall have the included protective sleeve slid over it once inside the enclosure. Then, insert grounding braid into grounding terminal.

Alarm Contacts
L or L1
N or L2
G

⚠ WARNING

The maximum allowable length of the RTD wire is 50ft. (15m) in order to remain UL/cUL compliant.

⚠ CAUTION

Enclosure lid must be properly sealed prior to operating. Each of the four (4) screws are to be evenly tightened by hand with appropriate screw driver ONLY until snug. It is recommended that the lid be secured with a torque of 12-15 inch-lbs per screw. Overtightening or uneven tightening may cause the lid to break which would void all environmental and hazardous location approvals. Due to an electrical shock hazard, do not operate thermostat if lid is cracked, broken or uneven with enclosure.

⚠ CAUTION

Be sure to install this device vertically as pictured. This controller utilizes a heat sink which is designed to cool the unit during operation. Under no circumstance should air flow around the controller be compromised in any way. Failure to do so may result in the overheating of the controller, product failure, product temperatures which exceed the Hazardous Area maximum temperature limit and even fire.

Start-Up

⚠ WARNING

For up to 30 amp loads, use minimum 10 AWG wiring or better for 120/277 VAC power input.

Connecting power to the unit.

1. Powering up with 120/277 VAC: To power up the unit apply 120/277 VAC to the terminal block according to the schematic below:

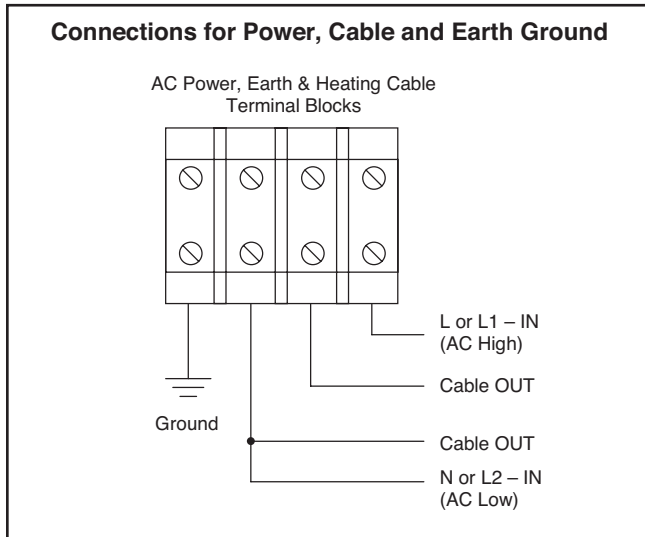

2. Programming with 9VDC battery:

The DTS-HAZ may be programmed with a 9VDC battery should standard service line voltage be unavailable.

Note: Powering unit with 9VDC should only be used for programming purposes and not operation of the unit.

⚠ WARNING

Programming of the 9 VDC battery shall not be done in hazardous locations.

3. Programming and alarm overview

Digital Thermostat must have the following components set to correctly control the temperature:

- a. Setpoint – targeted temperature value that controller will aim to reach
- b. Hi Temperature Alarm – Temperature at which the unit goes into high temperature alarm mode.
- c. Lo Temperature Alarm – Temperature at which the unit goes into low temperature alarm mode.
- d. Deadband – The allowable temperature differential between the Set Point and the Sensed Temperature during normal operation. The Deadband is centered on the Setpoint. The Deadband has a range of 2 to 10 deg. in 2 degree increments.

The Load is removed once the temperature is 1/2 way between the Setpoint and the upper limit of the Deadband.

- e. Temperature Units – selection between degrees Fahrenheit or Celsius.
- f. Soft Start Function – The soft start may be enabled or disabled. When enabled, the Soft start algorithm initiates at power on & whenever low end of dead band is realized. When initiated, 0% - 100% Power is achieved over 167 seconds.
- g. Alarm State – The FACTORY DEFAULT SETTING IS NORMALLY CLOSED. You may toggle this setting to Normally Open via the control push buttons.

Connecting RTD Wire

1. Connect RTD wire according to the schematic:

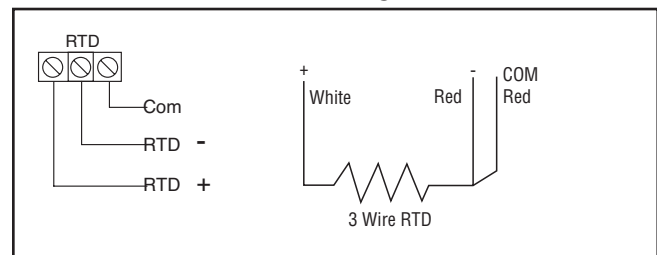

Alarm Wiring

The alarm on the DTS unit is a non-arcing, solid state relay. In order for it to properly function, it must be supplied with either AC or DC voltage, depending on which model is selected. The alarm on the DTS-HAZ functions only with AC voltage. The alarm on the DTS-HAZ-DC functions only with DC voltage.

DTS Alarm Wiring Options

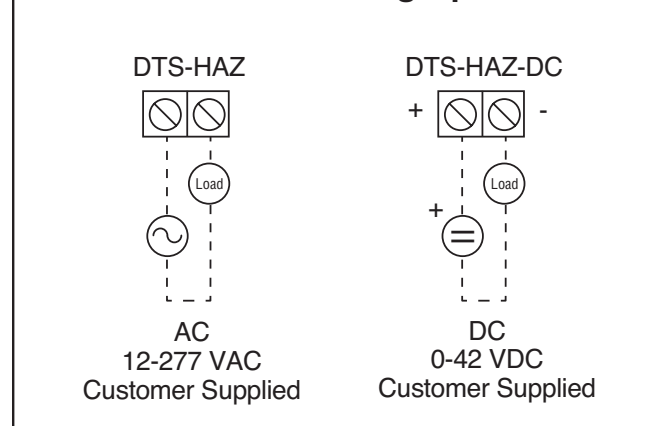

Programming

To Program the Digital Thermostat follow the instructions below:

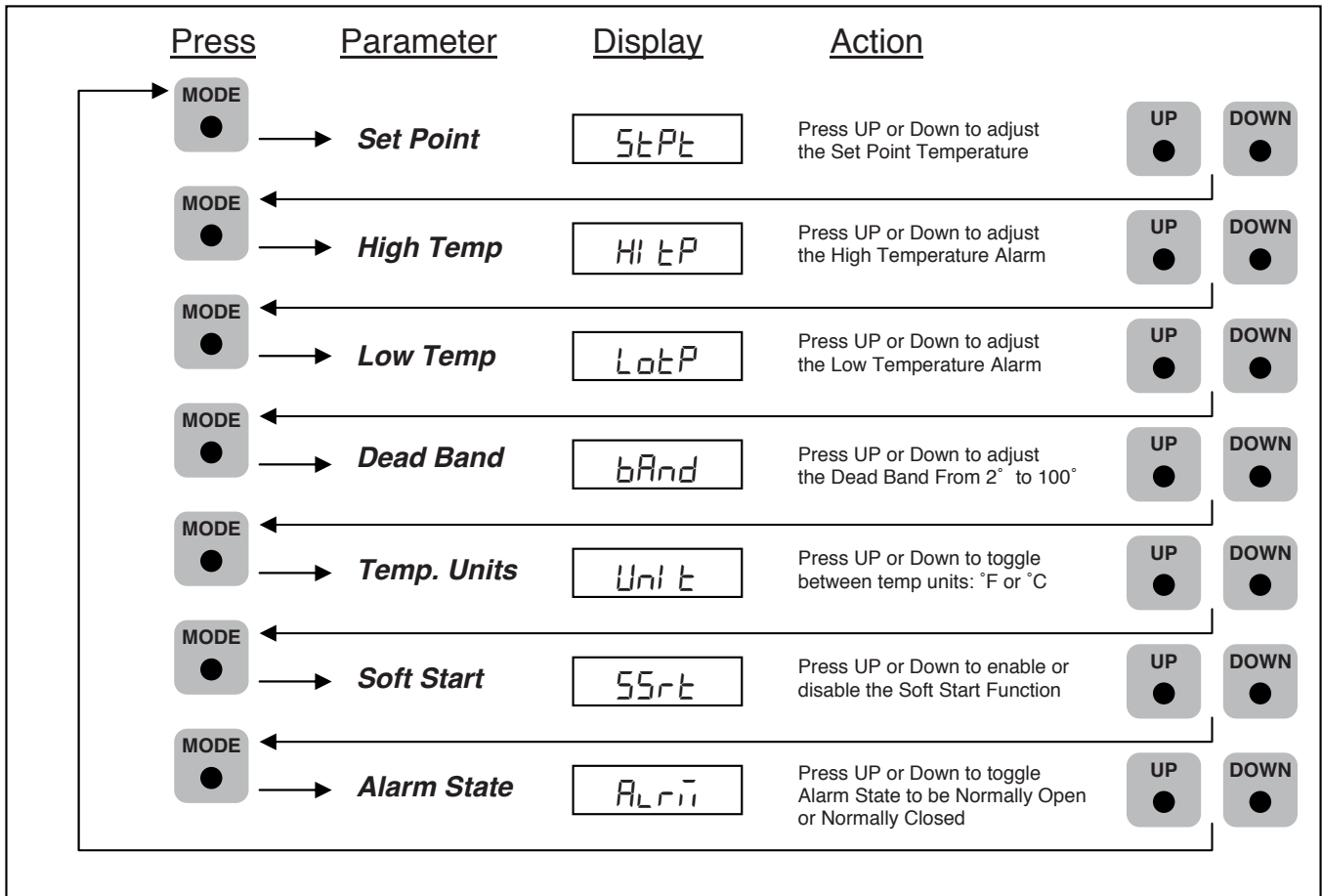

Troubleshooting

Alarm Type:	Display	Solution:
Sensor Open	Sens err	Check if your sensor is correctly connected to the unit
Sensor Shorted	Sens err	Check if your sensor is correctly connected to the unit
Lo Temperature	Blinking between sensed temperature and "Lo tP"	Sensed temperature is below Lo Temp. Threshold. Alarm will be cleared automatically when sens temp > lo threshold + 5 deg
Hi Temperature	Blinking between sensed temperature and "Hi tP"	Sensed temperature is above HI Temp. Threshold. Alarm will be cleared automatically when sens temp < hi threshold - 5 deg
EPR	EEprom memory error	Press UP & DOWN keys for 2 seconds. Unit will be loaded with default settings
ERR1	Program memory error	Program memory corrupt. Solution: Reprogram the unit. Consult Factory.

Optional Wall Mount Kit

The DTS-HAZ may be mounted on vertical surfaces. To maintain UL/cUL and Class 1, Division 2 compliance, the user must use the optional Wall Mounting Bracket Kit (MP-2 DTS-HAZ Mounting Plate Kit, part number 5120-13015).

Considerations:

1. The kit comes complete with two stainless steel mounting brackets and the necessary hardware to mount the brackets to the DTS-HAZ.
2. Should the owner use other means to mount the DTS to a vertical surface, a minimum of 3 inches or 76 mm must be maintained from the rear of the DTS-HAZ to the mounting surface. This is necessary to provide adequate airflow across the heat sink at the rear of the DTS.

3. When installing the DTS on a vertical surface, the Pipe Standoff is not used and is typically replaced by rigid 1" NPT conduit. The conduit shall terminate into the Compression Fitting.

Ordering Information:

Wall Mount Kit PCN (Part Number): 318043

Stainless Steel Hardware:

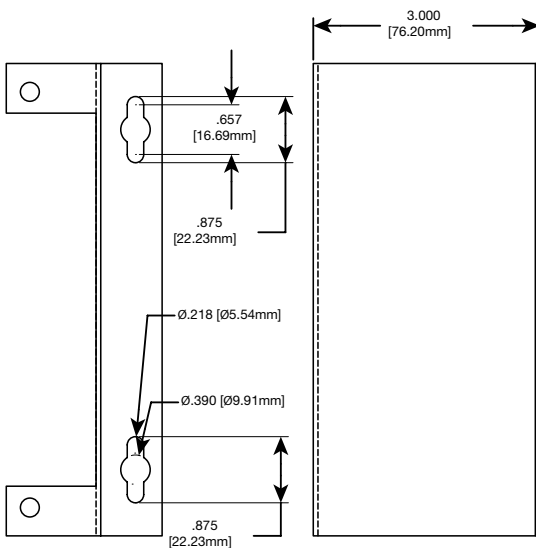
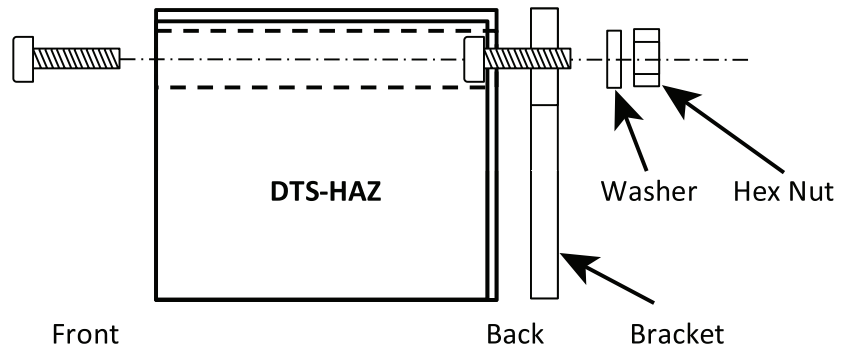
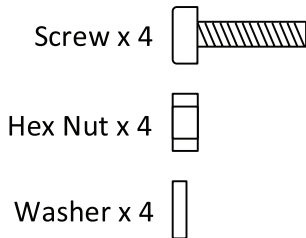

RECOMMENDED - WALL MOUNT LAYOUT MAXIMUM #10 STUD

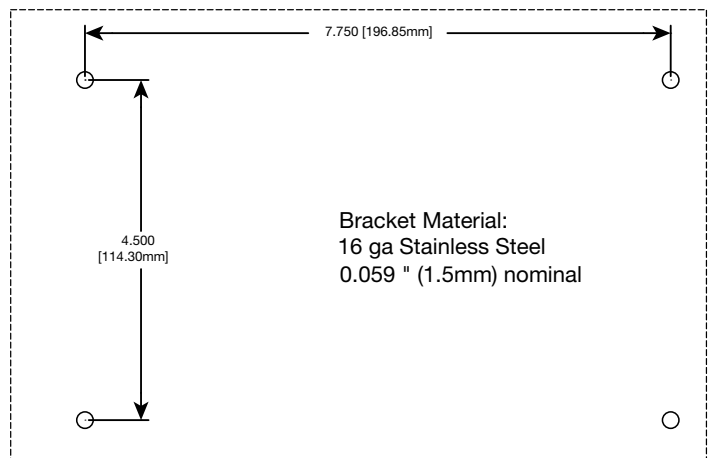

Product Maintenance & Care

The following inspections should occur upon receipt of product and at least once every year.

a. Wiring

Inspect wiring for wear, fraying and evidence of overheating. Repair minor defects with a high quality grade of electrical tape or replace if needed.

b. Hardware & Connectors

Inspect for loose electrical and mechanical connections. Tighten or replace all loose or missing hardware.

c. Cleaning

This product does not require cleaning. However, the heat sink fins on back must routinely be inspected for any debris. Remove any debris with a stiff brush or other careful means. Take care not to break any fins. Should any of the fins break, the unit should be replaced.

⚠ WARNING

EXPLOSION HAZARD. Substitution of any component may impair suitability for Class 1, Div. 2.

Equipment Ratings:

Voltage Rating: 120-277 VAC, 50/60 Hz

Current Rating: 30 amps

Ambient Temp. Rating: -40°F to 104°F (-40°C to 40°C)

Alarm Rating:

- DTS-HAZ: 12-277 Vac and 1.8 Amps RMS
- DTS-HAZ-DC: 0-42 Vdc and 1.8 Amps RMS

VA rating on electronics: 4.0 Watts

The electronics are protected by a 0.125 Amp 350 VAC 2AG fuse

Maximum RTD output 1.25 volts, 7 milliamps

Temperature Rating: UL-T4a, IEC/ATEX-T4

Protection: IP66

Settings:

Setpoint: -80°F to 1100°F (-62°C to 593°C)

Alarms: High temp to 1150°F (621°C)

Low temp to -80°F (-62°C)

Deadband: 2°F (or °C) to 100°F (or °C)

+/- 1° to 50° around the setpoint

Alarm Function:

Mode	Default	Optional
Normal Operation	Closed	Open
Alarm Condition	Open	Closed
Power Off	Open	Open

Agency Approvals:

UL:

- UL/cUL - Hazardous area (Class I, Div. 2, Groups A,B,C,D)
- Temperature Rating: T4A
- UL File number E347725 (Ordinary areas are covered by the hazardous area file)

IECEX & ATEX:

- II 3 G Ex nA nC IIC T4 Gc IP 66
- Ex nA nC IIC T4 Gc IP 66
- ITS15ATEX48203X
- IECEX ETL14.0012X
- Temperature Rating: T4

CE

Field Wiring Considerations:

Torque values for field wiring terminals 11-15 in-lbs
(1.2 - 1.7 n-m)

Wire gauge range 6 - 18 ga

Stripped insertion length 1/2" (12mm)

Replacement Parts

Fuse

Specifications 0.125A, 350V, 2 AG

Dimensions 14.18 mm (L) x 4.5 mm (W)

Material Glass

Vendor & Model Bel Fuse, 2JS 125-R

Replacing Fuse:

⚠ WARNING

HAZARD OF ELECTRIC SHOCK. Turn off power before removing junction box cover.

1. Remove Cover.
2. Carefully remove display board from 4 nylon posts.
3. Fuse is in upper left corner of bottom board.
4. Carefully remove the bad fuse and replace with new fuse.

Limited Warranty:

Please refer to the Chromalox limited warranty applicable to this product at <http://www.chromalox.com/customer-service/policies/termsofsale.aspx>.

**Chromalox, Inc.
1347 Heil Quaker Boulevard
Lavergne, TN 37086
(615) 793-3900
www.chromalox.com**