



Introduction

This instruction manual is designed as a guide to the proper installation and operation of a ProTherm Heated Hose with electrical heating element. The user should familiarize themselves with this manual before installing and operating the heated hose. Improper installation and operation could damage the product. The instructions and suggestions provided in this manual are for typical applications seen with these hoses. The hose label indicates the type of heated hose and any installed options. Contact your ProTherm representative for additional information on special designs and applications

Hazard Symbols

The following symbols are used in this manual to show items of special interest.

Caution Caution - The user should be instructed in the proper procedure before continuing.



Caution - Surfaces may be hot

Warning Warning - Improper action may cause severe damage to the product or injure personnel.



Caution - Dangerous voltages may be present.



Warning - Improper operation could result in a fire hazard.

General Product Information

- Prior to use, check the hose for worn or damaged outer jacket, damage to the power sleeves and tube and couplings. Any damage should be reported to the responsible person before hose is used.
- These products are designed to be used in an engineered system. The customer is responsible for correct wiring to the electrical supply and for correct fusing to meet all electrical codes. See the section on electrical installation for further information.
- This product has no user serviceable parts. Do not remove the outer jacket, cut, or modify this product.
- The hose label provides information on supply voltage and current draw to assist in proper sizing of fuses and electrical wiring.

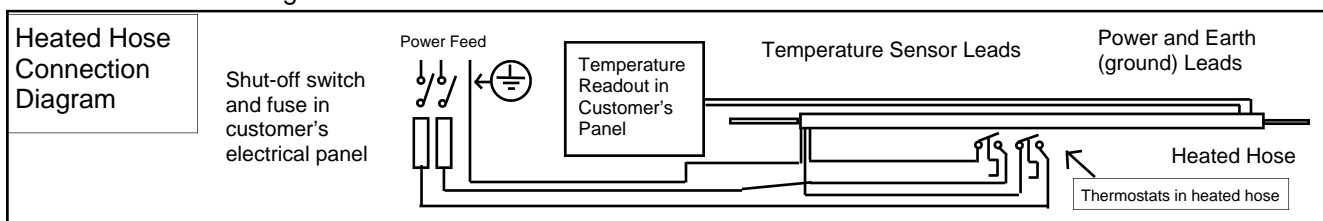

Safety Precautions for Heated Hoses



Observe all electrical codes and standards when installing and using these products. These products do not contain user serviceable components.



Warning Contents of heated hose may be hot and under pressure. Do not loosen hydraulic connections when hose is operating.



Caution Metal fittings on hose will be very hot during operation.



Do not operate these hoses in any area classified as "Hazardous", or "Explosive".



Caution Heated Hoses must be controlled to prevent overheating. Check hose labels for proper sensor type.



Turn off all power before disconnecting or servicing heated hose.

Unpacking

Short hoses are shipped flat, in cardboard cartons. Longer hoses are shipped on wooden reels.

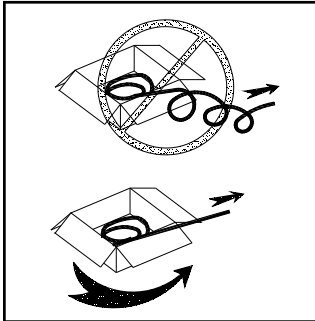

Check for damage to the carton or reel before opening. Damage to the container may indicate damage to the hose. This may make the hose inoperative or unsafe. Report any damage to the carrier. Care should be taken when removing hoses from cartons to prevent twisting or kinking the hose. Rotate the carton or walk around the carton when removing the hose. Reels should be placed on a freewheeling stand and paid off by hand. Do not pull the hose off the reel over the flange.

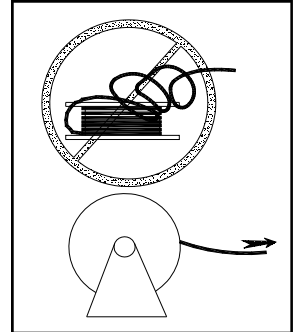

Installation

It is important to understand that hoses longer than 10m (33 ft.) cannot support their own weight. These hoses should not be pulled into place, but positioned carefully.

Do not use hose couplings to pull, lift, or support the hose during installation.

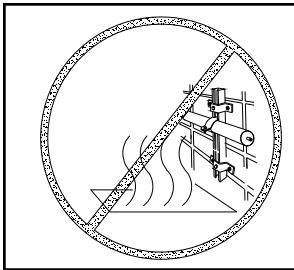

The routing for heated hoses should be chosen to take advantage of existing structures and supports.

Hoses must not be routed through or near areas where the temperature exceeds 50° C (120°F), such as near boilers, furnaces or steam lines, unless the hose was specifically designed for that temperature.

When installing more than one heated hose on the same support, or when routing heated hoses alongside other hoses, cables, or pipes, allow 25 mm (1 inch) space between the heated hose and the other lines to prevent overheating.

Do not bundle, coil, or overlap hose(s) during operation, and do not set items on top of a heated hose. This will also cause the hose to overheat.

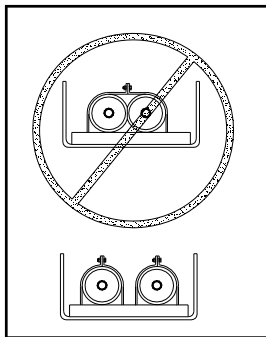

If the hose is secured to a structure, use a clamp with a wide surface and do not collapse the insulation.

If the hose is used for a portable application, like a glue gun, insure that it is protected from damage from being walked on or run over.

Do not bend the hose tighter than the minimum bend radius shown on the hose label. Tight bends may damage the hose core or the electrical heater.

If a hose must be installed in a vertical run too high to be positioned by hand, a wire pulling grip can be used.

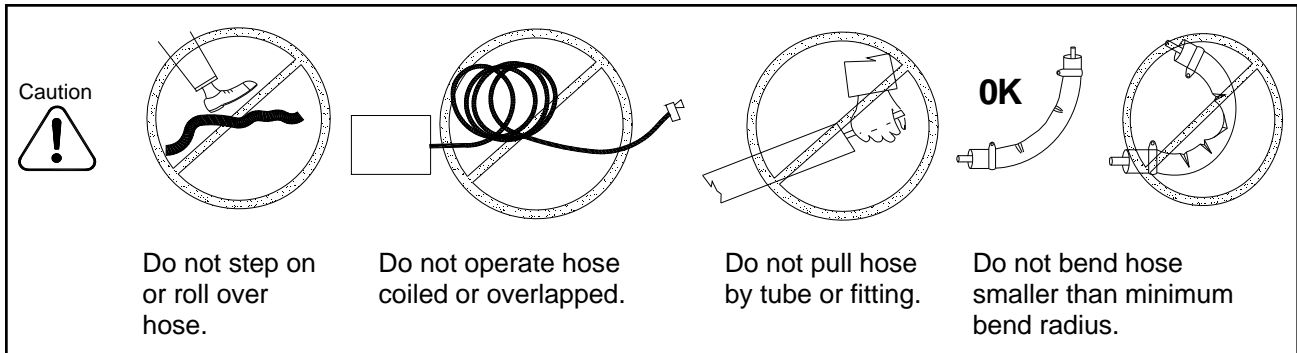

Electrical Connection

Tags and Labels

Labels and tags at both ends of the hose that tell about the hose design and operation.

The label shows the model number, design number, voltage, total current draw, total heating power in watts. The tag shows the color code for the power and messenger wires in the bundle. Review the labels before connecting the hose to power. Wiring the hose incorrectly can cause an electrical short circuit and damage the hose.

Do not operate the hose at a voltage higher than shown on the label. This will cause the hose to overheat.

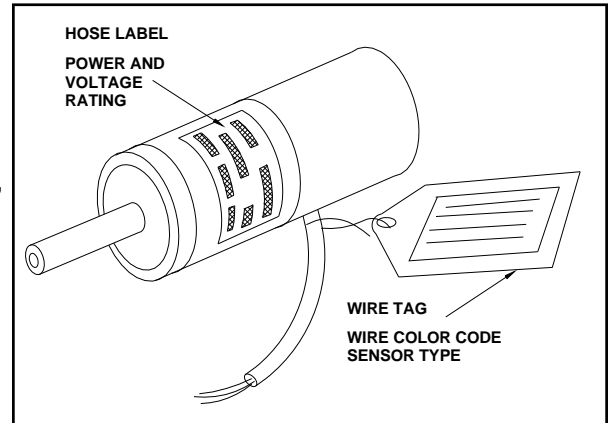

Caution



Tags are attached to provide additional information on special designs. **Do not remove tags from heated hose.**

Electrical Wiring

ProTherm Heated Hoses can be supplied with insulated wire leads to connect to an approved terminal block in the customer's electrical control panel. The type of connector is specified by the design and customer requirements. Contact your sales representative if the correct electrical termination is not supplied on your hose

The insulated conductors used in ProTherm Heated Hoses are rated at 200°C or higher, 300 VAC. The color code for the heater power wires is indicated on the tag affixed to the power sleeve. The protective earth connection is green to allow it to be attached to the customer's panel.

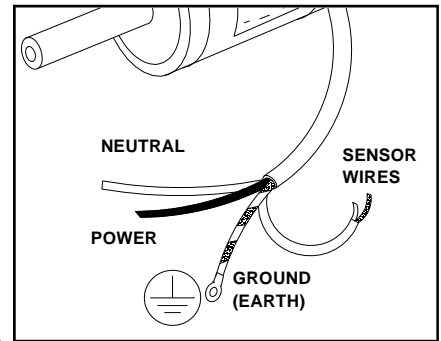

Heated Hoses, like all electrical equipment, should be connected to proper overcurrent protection. The hose label will indicate the maximum operating power and current required for the hose to assist in selection of the proper fuse or circuit breaker size. Overcurrent protection should meet all electrical codes for the application and location.

Ground fault circuit protection may be required in some applications. This should be selected to meet required codes.



Wiring should be performed only by skilled persons. Dangerous voltages may be present in the customer's panel. Power to the hose or controller must be disconnected before performing any electrical maintenance.

Electrical circuits are tested prior to leaving the factory. The customer can confirm the heater resistance by testing across the power and neutral leads with a good resistance meter. The resistance should closely equal the supply voltage divided by the total current draw. These figures are printed on the hose label.

There should be an open circuit between the power leads and ground. Improper readings should be investigated before powering the hose.

Temperature Sensors

Protherm bundles are supplied with a sensor to control the bundle temperature. The illustrations below show the most common types of sensors used in ProTherm bundles and how to determine which type is installed. Refer to the instructions for the temperature controller to insure that the proper type of sensor has been specified. These instructions will also show how to correctly connect the sensor to the temperature controller.

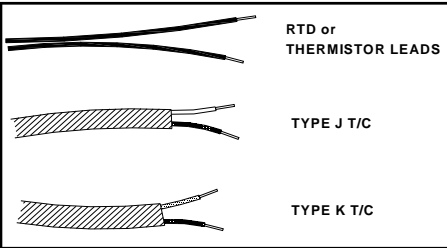
	Sensor Type	Lead Resistance	(+) Leg Color	(-) Leg Color	Lead Type
	Pt 100 RTD	100-130 Ohms	Black	Black	Insulated Wires
	Type J Thermocouple	1-10 Ohms	White	Red	Wire pair with overall jacket
	Type K Thermocouple	1-10 Ohms	Yellow	Red	Wire pair with overall jacket
	Cust Supplied	Depends upon	Blue	Blue	Insulated Wires

Hydraulic Connection

Tube end heated hoses are supplied with bare tube ends which are connected directly to the customer's compression type fitting. This eliminates any potential leakage problems that can occur in some applications.

JIC heated hoses are supplied with JIC female swivel couplings, which are permanently connected to the hose core.

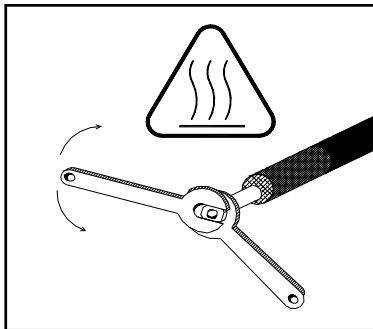

These couplings are supplied with a wrench hex behind the swivel fitting. Use 2 wrenches when coupling and uncoupling these hoses to prevent twisting the hose core.

Hoses used to convey hot wax, adhesive, or other similar materials must be uncoupled when hot.

Warning



Use extreme caution if uncoupling hoses filled with hot materials. Do

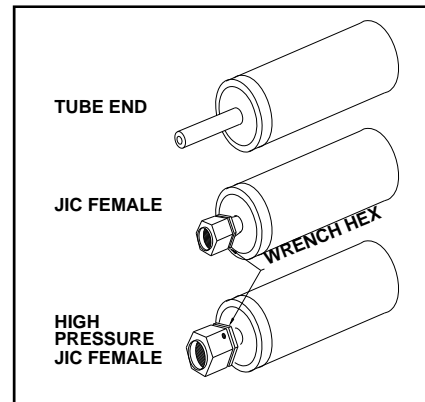

Operation

- Heated hoses must be connected to a temperature controller or thermostat for proper operation.
- Allow the hose to heat up fully before use. If the hose has been used to transport glue or other viscous fluids, the hose must be allowed to soak at the application temperature long enough to melt the material in the fittings. Failure to allow proper soak time may result in damage to the hose and possibly a break in the hose core.
- Do not cover the heated hose with additional insulation. This will cause the hose to overheat.
- Insure that the fluid entering the hose is at a temperature below the maximum use temperature of the hose, as called out on the hose label. Excessive fluid temperatures can damage the hose.

Technical Assistance

For additional information or technical assistance, please contact your ProTherm at 615-834-4044

Glossary of Terms

These are some of the special terms used in this manual.

Annular Convolute	This hose uses a series of ridges and valleys to improve the flexibility of larger diameters. The inside of the hose looks like an accordion.
Cable Ties	Metal or plastic self-fastening straps used to attach wires and cables to pipes and other support structures.
Cable Tray	Typically, a metal structure that looks like a ladder laid flat. Used to hold multiple heated hoses.
Compression Fitting	A replaceable hydraulic fitting use to connect tubing with a smooth outer diameter. The tube is captured by one or more rings that are pressed against a similar surface to seal the connection.
Corrugated Steel Hose	A flexible steel tubing product made by bending a steel tube in a series of waves. A metallic braid is added over the corrugated tube to allow the tube to be used at higher pressures.
Felted Insulation	A non-woven flexible thermal insulation made by bonding many layers of material together. No glues or binders are used in this insulation.
Flange Fitting	A permanent hydraulic fitting used on large diameter hoses and in some sanitary or pharmaceutical applications. The fitting is bolted or clamped to a mating fitting to provided the seal.
Fleet End	The discharge end of the hose.
GFCI	Ground Fault Circuit Interrupter - A device used to open the electrical circuit in case of damage or loss of electrical insulation.
Hazardous Locations	Locations and areas classified by the Regulating Authority where there is an increased chance that fire or explosion could occur in normal and abnormal conditions. These areas generally require additional safety precautions for electrical
Helically Convolute	This hose uses a series of ridges and valleys to improve the flexibility of larger diameters. The inside of the hose looks like a screw thread.
JIC Fitting	A permanent hydraulic fitting used on all sizes of hose. The fitting features a 37° tapered seat. Also known as the "AN" fitting. This fitting is excellent for liquids and gasses.
Messenger Wire	A wire or cable that is installed in the hose but used to sense or control a device at the fleet end of the hose.
Ordinary Locations	Locations and areas classified by the Regulating Authority where there is no increased chance that fire or explosion could occur in normal and abnormal
PFA	A high temperature fluoropolymer resin used in tubing. This material has a temperature rating of 450°F (232°C) and is inert to most chemicals.
Pipe Fitting	A tapered screw-type hydraulic fitting used in fluid applications. The seal is provided by contact between mating screw threads. This fitting is not recommended for gas applications.

Glossary of Terms (cont.)

Power End	The inlet end of the hose. This is generally the end with the power wires.
Power Sleeve	A metal or rubber sleeve that exits the power end of the hose and contains the insulated wires used to provide electric power to the heater. This sleeve may also contain wires for the hose temperature sensor, and messenger wires.
PTFE	A high temperature fluoropolymer resin used in tubing. This material has a temperature rating of 450°F (232°C) and is inert to most chemicals. It does not melt at high temperatures.
RTD	A highly accurate temperature sensor used in heated hoses. This device changes resistance in response to changes in temperature. The RTD sensor is available in 2, 3, and 4 wire versions.
Series Resistance Heating Wire	This describes a number of alloy heating wires used in heated hose constructions. The wire alloy and sized is varied to achieve proper resistance for the power required and the length of the hose.
Strut Clamps	A type of wide bearing metal clamp used to anchor and support heated hoses. This type clamp is specially designed for use with metal framing channel.
Thermistor	A special temperature sensor used with some electronic controllers. Thermistors are designed to operate within narrow temperature ranges. They must be specified exactly for the temperature controller being used. Unitherm generally requires the customer to supply any thermistors used in our heated hoses.
Thermocouple	A class of general purpose temperature sensors used in the industry. Thermocouples are constructed of two dissimilar metal wires or strips. The thermocouple generates a small voltage that can be converted to temperature. This sensor is not as accurate as the RTD, but it is very rugged and inexpensive to use. Thermocouples are used in the majority of heated hose products.
Wire Pulling Grips	A wire mesh sleeve with pulling "ears". The pulling grip is slipped over the heated hose and the ears attached to a pulling cable. The mesh sleeve contracts when pulled and grips the outer jacket of the heated hose. This device is used when heated hoses must be installed in vertical runs; for example, on the side of a smoke stack.



"Industrial Heaters, Sensors & Controls"

Phone:(615) 834-4044
Fax:(615) 834-5834

WWW.PROTHERMIND.COM
protherm@comcast.net

Order Our Products Online at
www.HeatingElementsPlus.com

